

## INSTALLATION INSTRUCTIONS

DESCRIPTION: Radiator Guard Kit

PART NUMBER: B9T-E24D0-V0

MODEL: 2020+ MT-03



### **⚠ WARNING**

Please read and understand these instructions completely before installation to avoid possible injury, or damage to the accessory or vehicle.

### **NOTICE:**

Installation of this kit requires a torque wrench and should be performed by an authorized Yamaha dealer or a qualified mechanic.

### **WARRANTY INFORMATION:**

In the United States, see your Yamaha dealer for a copy of the Yamaha Genuine Parts and Accessories Limited Warranty.

### **DEALER OR INSTALLER:**

These instructions contain important information for future reference and *must* be given to the customer.

## PARTS LIST:

No.	Part Number	Description	Qty
--	<b>B9T-E24D0-V0</b>	Radiator Guard Kit	-
①	-	Radiator Guard	1
②	-	M6x30mm Bolt	4
③	-	Spacer	4
④	-	O-ring	4

\* Part supplied with kit only and not available separately.



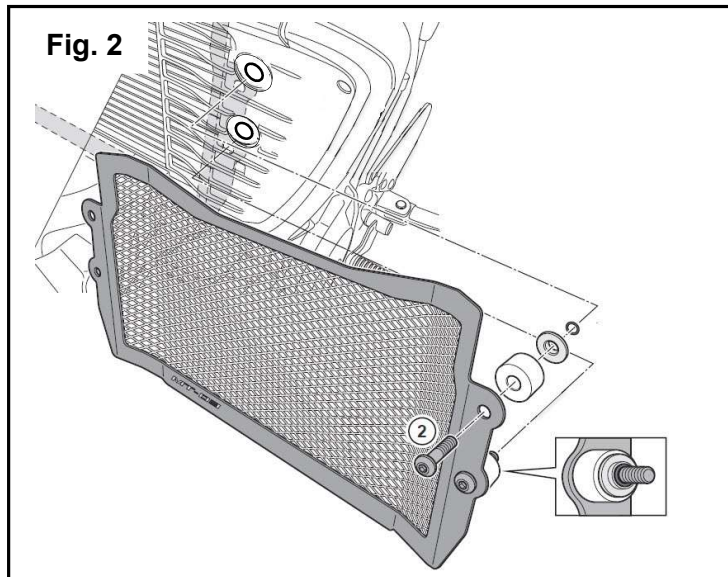
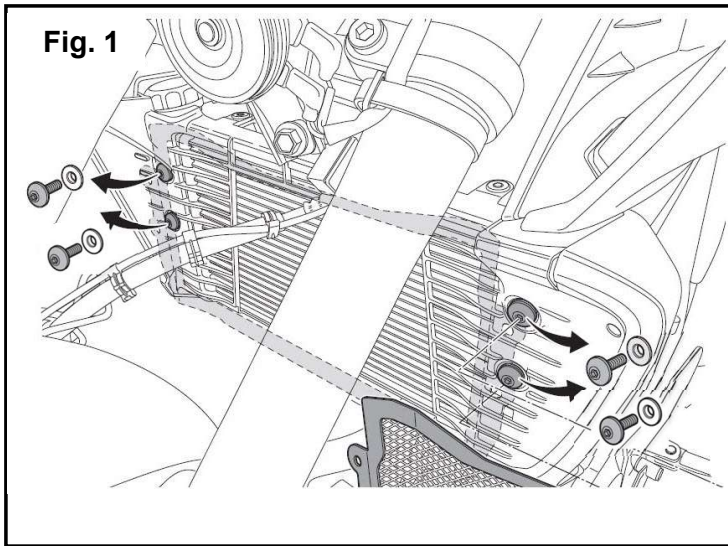

### PREPARATION:

- Place the vehicle on a secure and level surface.
- Clean the radiator mount surfaces before beginning installation.
- The engine and radiator must be cool to the touch before starting the installation.

### INSTALLATION:

1. Remove the stock hardware from the radiator side guards. (Fig. 1)
2. Retain the washers for reuse. (Fig. 1)
3. Insert one (2) M6x30mm Bolt through one of the outer holes on the (1) Radiator Guard. (Fig. 2)
4. On the (2) M6x30mm Bolt, stack a (3) Spacer, stock washer and an (4) O-ring on the back side of the (1) Radiator Guard. Repeat this assembly at the other mounting locations. (Fig. 2)
5. Align the (1) Radiator Guard over the radiator.
6. Thread the hardware into the stock locations.
7. Torque all hardware to 8 Nm (0.8 kg-m or 5.9 lb-ft).

### MAINTENANCE:

Periodically, check torque on all hardware. If loose hardware is found, re-torque to specification.

### CARE AND CLEANING:

Clean painted metal parts with a clean soft cloth and mild soap and water solution. Rinse and dry.

### CUSTOMER SERVICE:

For further information see your Yamaha dealer.

**ESTIMATED TIME TO INSTALL: 0.5 HRS.**